

**16 Gauge™**  
304 Premium Stainless Steel

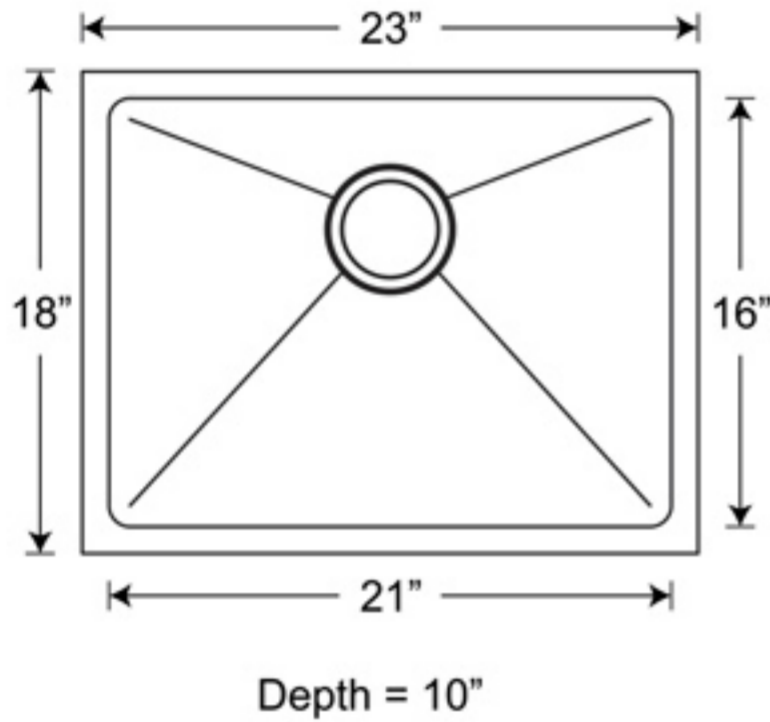

**ACCESSORIES INCLUDED**

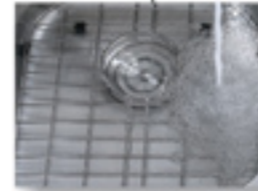

01 Bottom Grid



01 Strainer & Basket



01 Cutting Board



01 Salad Bowl

This model is made from durable 16 gauge 304 premium stainless steel, highly resistant to heat, most household stains, and rust for the life of the product.

**CHEF-Z101 - CHEF ZERO SERIES**

- Undermount
- Premium stainless steel 304
- 18/8 chrome nickel content
- 20mm/0.75 radius coved corners
- Pro-Vest™ undercoat protection over Sound Shield™ pads
- Template and mounting hardware included
- Satin finish - Fits 27" cabinet
- 3 ½" drain opening
- Optional accessories: SIS-COLANDER

**SINK FEATURES**



Stone sinks feature Sound-Shield pads on several strategic areas of every sink for extra sound proofing. Made of natural rubber, the Sound-Shield pads reduce the noise of clattering dishes and running water.



Pro Vest is a protective coating over the Sound-Shield pads. This system reduces noise, prevents condensation, and helps maintaining water temperature when pre-soaking dishes.



All Stone sinks receive expert hands-on care under strict quality control throughout every stage of our modern manufacturing process. This ensures a "NO HASSLE" Limited Lifetime Warranty against all manufacturing defects in material and workmanship under normal use. Please read our Limited Lifetime Warranty policy at our web site: www.StoneUsa.com.

**CODE / STANDARDS COMPLIANCE**

Most Stone sinks meet or exceed the following specifications:  
ASME 112.19.3-2008 - IAPMO/UPC listed - CSA B45.4-2008



**OPTIONAL ACCESSORIES**

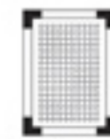

SIS-COLANDER  
Stainless Steel  
Colander



**JOB INFORMATION**

JOB NAME: \_\_\_\_\_ MODEL SPECIFIED: \_\_\_\_\_ QUANTITY: \_\_\_\_\_  
 DATE: \_\_\_\_\_ ARCHITECT/ENGINEER: \_\_\_\_\_  
 CUSTOMER: \_\_\_\_\_ CONTRACTOR: \_\_\_\_\_